

# LevelLite

Lightweight Liquid Level Sensor

## Manual



# Contents

<b>1. Product description</b>	<b>3</b>
<b>2. Getting started</b>	<b>5</b>
2.1 Primary output	5
2.2 Secondary output	5
<b>3. Configuration</b>	<b>6</b>
3.1 Tank profiling	7
<b>4. Installation</b>	<b>8</b>
4.1 Parts supplied	9
4.2 Cable length & strain relief	9
4.3 Fitting the mounting adaptor	9
4.3.1 Fitting the 19 x 1.5 mm fluorosilicone O-ring seal	9
4.3.2 Fitting the sensor adaptor	10
4.3.3 Fitting the fluorosilicone panel gasket or fluorosilicone 13 x 1.5 mm O-ring seal	11
4.4 Recommended mounting aperture for adaptors	12
4.4.1 For O-ring seal with 1, 2, 3 and 5 hole mounting adaptors	12
4.4.2 For panel gasket with 2, 3 and 5 hole mounting adaptors	13
4.5 Mounting adaptor hole layout	13
4.5.1 One Hole mounting adaptor	14
4.5.2 Two hole mounting adaptor	14
4.5.3 Three hole mounting adaptor	15
4.5.4 Five hole mounting adaptor	15
4.5.5 M22 x 1.5 mm threaded flange mounting adaptor	16
<b>5 Specifications</b>	<b>17</b>
5.1 General	17
5.2 Environmental	17
5.3 Mechanical	17
5.4 Electrical	18
5.5 Connection	18
5.6 Part number configuration	18
<b>6. Maintenance, returns &amp; de-commissioning</b>	<b>19</b>
6.1 Maintenance	19
6.2 Returns	19
6.3 Decommissioning	19
<b>7. Appendix</b>	<b>20</b>

## 1. Product description

LevelLite Lightweight Liquid Level Sensor is designed for use in punishing environments, such as motorsport, industrial and defence applications, where low weight and high accuracy are required. With side or top cable exits and multiple mounting options, the sensor is ready for use in a wide variety of containers for fuels, oils and coolants across a wide temperature range. The sensor has no moving parts, floats or mechanical linkages providing excellent long term reliability.

Liquid level detection is achieved through solid-state capacitive technology. An outer tube and inner rod act as the plates of a capacitor, with any liquid providing the dielectric between the two. As the liquid level rises and falls, the capacitance of the sensor changes linearly. The on-board electronics process this and provide an output as an analogue voltage signal.

The sensor electronics are housed in the flange, outside the liquid container. The outer tube and inner rod are placed into the liquid container, such that they will be submerged in liquid (when the container is not empty). Calibration of the sensor is achieved by setting a maximum (full) and minimum (empty) level for the desired liquid. The liquid level between these points is determined using software while taking account of the dielectric constant value of the liquid.

A variety of standard and custom mounting options are available on request to allow for the most suitable sensor installation method. Please contact Gill Sensor & Controls Limited for assistance. Your chosen calibration has passed through Gill Sensors & Controls Limited's quality control to ensure the sensor provides market leading measurement accuracy in your specified liquid.

The sensor is designed to operate in fluids where deposits or build-up of sediment are not expected, as this may block the bleed holes unless they are regularly maintained. For fluids where deposits or build-up of sediment are expected, please contact Gill Sensors & Controls Limited for a suitable sensor.

**Safety Warning, This equipment is not ATEX certified and has not been designed for use in areas which fall within the scope of the ATEX directive. If an area of intended usage is within the scope of the ATEX directive, then contact Gill Sensors & Controls Ltd for further information.**

A breakdown of the sensor, in both side and top cable exit variations, is provided below with key measurement considerations.

Top exit:

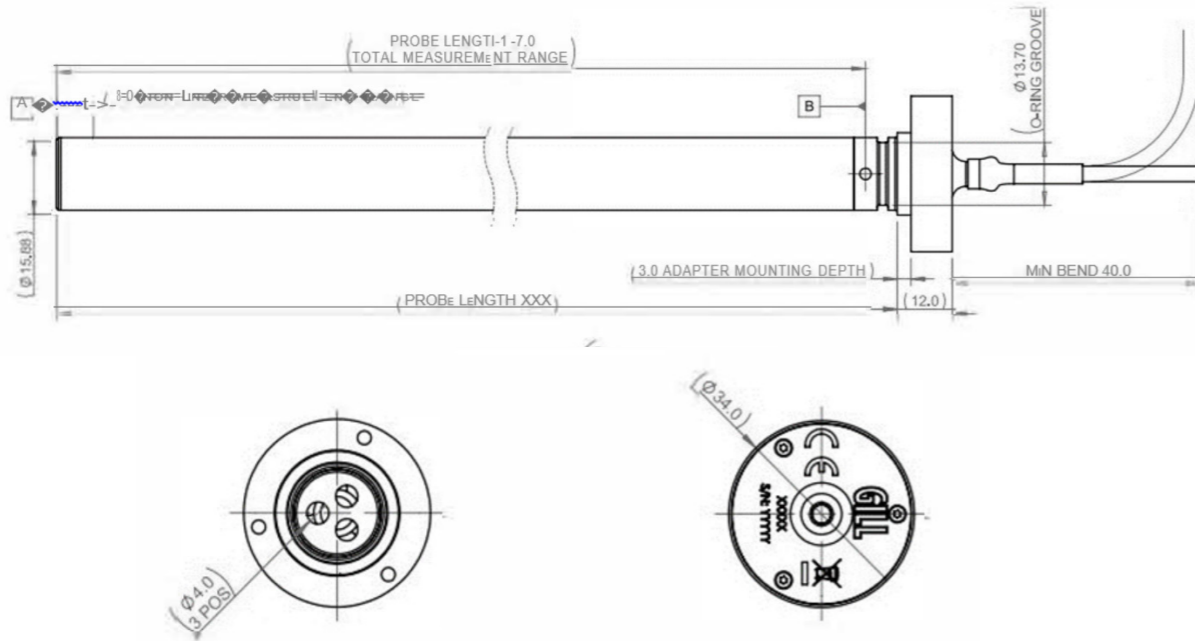

Side exit:

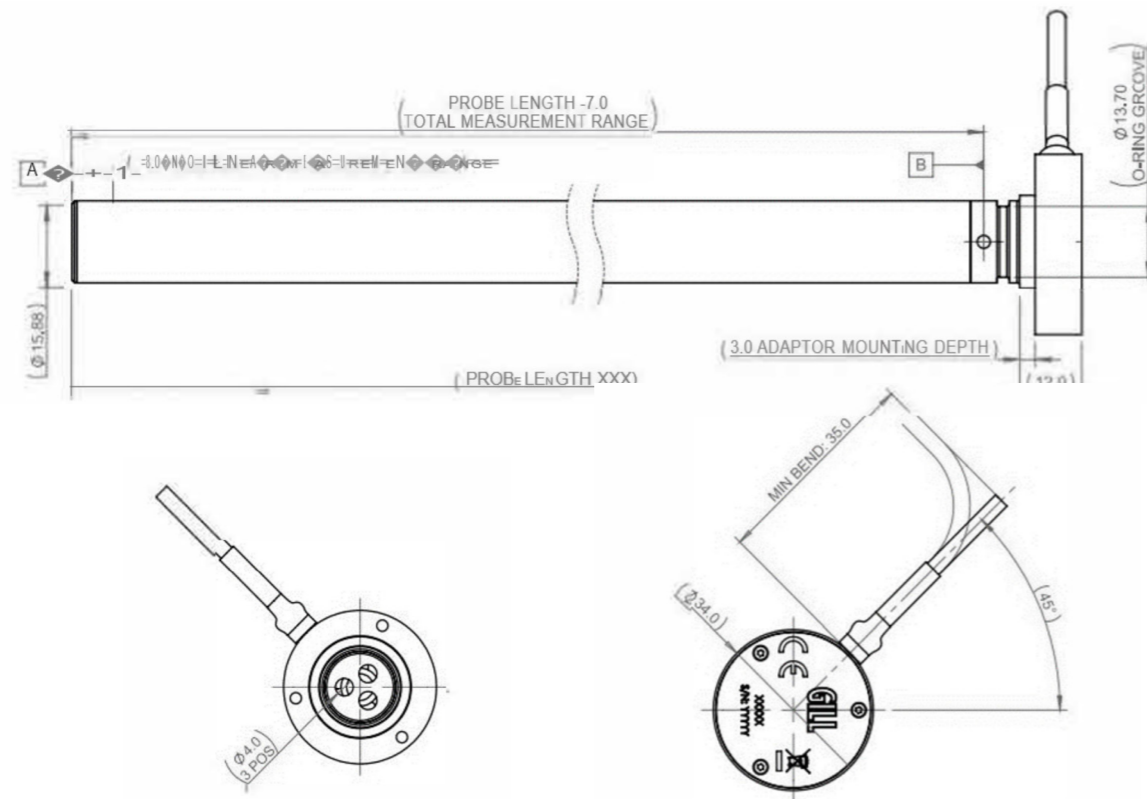

**2. Getting started**

The analogue output cable has six wires:

RED	+V (5-32VDC)
BLACK	-V (Ground)
ORANGE	Primary output (0.25 to 4.75VDC)
BLUE	Secondary output (refer to datasheet)
GREEN	RS232 Rx line
WHITE	RS232
SILVER	Drain Wire

Supply Voltage: +5 to +32 VDC

Supply Current: <20 mA

**2.1 Primary output**

The sensor will be provided with a factory calibrated output range of 0.25 V to 4.75 V. The sensor can be configured to a maximum output range of 0.25 V to 10 V.

The power supply must be at least 0.5V greater than the maximum output voltage required. The switch output requires a pull-up resistor of 1 kOhm to 10 kOhms.

**2.2 Secondary output**

The sensor's secondary output is determined by the customer on order and cannot be altered.

**Switch:**

Open collector output of 50V / 1A max switch to -V (ground) Configurable through user software  
Units with switch output have part numbers 4223-00-XXN-XXXX

**Temperature:**

0.25 V to 4.75 V where 0.25 V = -40°C and 4.75 V = + 125°C

NOT configurable through user software

Units with temperature output have part numbers 4223-00-XXY-XXXX

### 3. Configuration

The sensor can be configured using GSlevel software, available from [www.gillsc.com/support](http://www.gillsc.com/support). Select the product from the dropdown list.

The minimum operating system requirements are:

- 32-bit (x86) or 64-bit (x64) processor Windows® 7 or later
- 1 Gb RAM
- 500 Mb disk space
- One free USB port to connect a sensor

A connector is required to configure the sensor with a computer. Gill Sensors & Controls Limited can provide an RS232 to USB adaptor (P/N 1484-00-086). The sensor can be powered through the adaptor using the +V and -V leads and communicated with using the Tx and Rx leads. Please contact us if you require this device.

The GSlevel User Manual is accessible through the software. Install and run the software, then click the 'Help' button in the bottom right of the window, shown in the screenshot below.

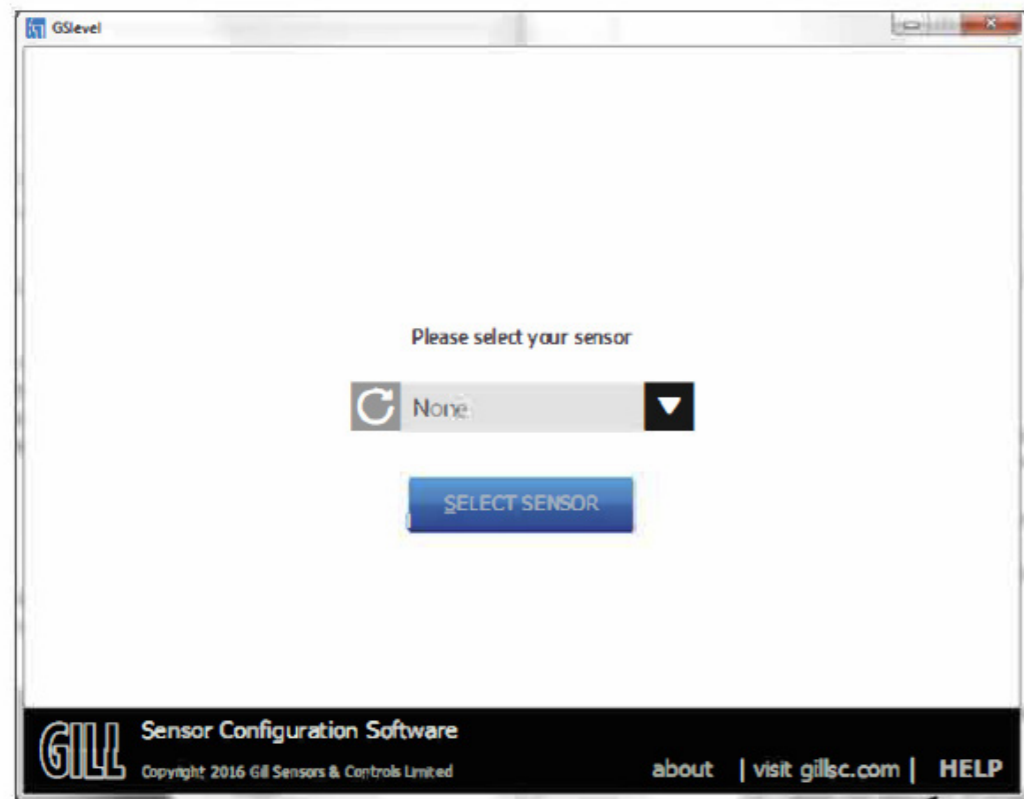

Click for GS level user manual

### 3.1 Tank profiling

The sensor is configured for use with regular tank profiles, such as that shown below.

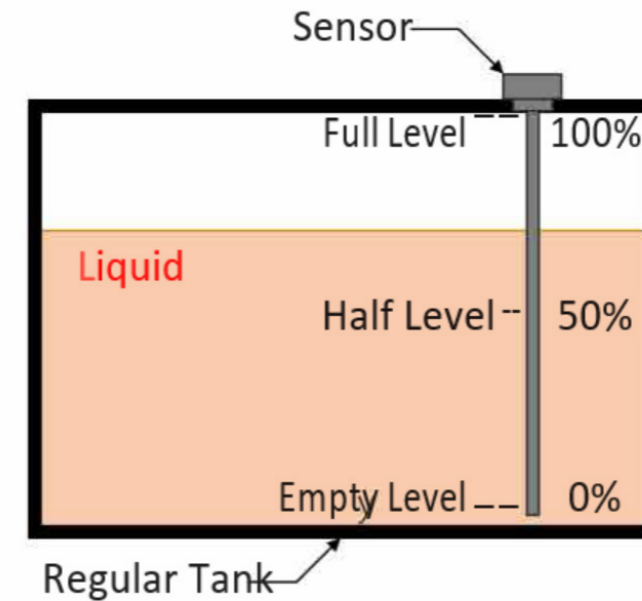

The sensor is supplied so that it reports the level in a linear path as the level rises. However, this will not be suitable for an irregular shaped tank, such as that shown below.

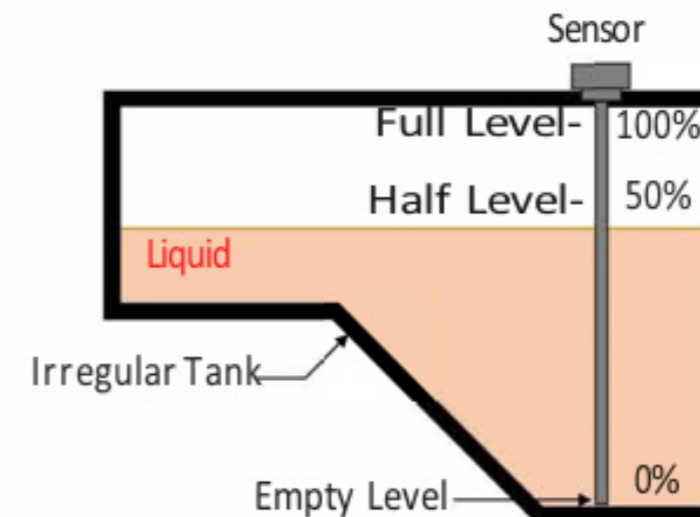

In this situation, 50% of tank volume is not half way up the probe. To correct for this tank profiling can be used. This can be done in the GSlevel software and is covered in detail in the GSlevel User Manual.

#### 4. Installation

Do not remove the packaging until you are ready to install the sensor. Prior to installation, please check the sensor for any signs of transit damage. Contact Gill Sensors & Controls Limited immediately if this is the case.

**Safety Warning**, This equipment is not ATEX certified and has not been designed for use in areas which fall within the scope of the ATEX directive. If an area of intended usage is within the scope of the ATEX directive, then contact Gill Sensors & Controls Ltd for further information.

DO NOT attempt to cut the sensor to length or bend the sensor. Both actions will result in the sensor failing and will invalidate the warranty.

The sensor must not be used in a tank that is not adequately vented.

The sensor flange and cable should not be immersed in the liquid.

Diagrams in this section are not to scale and are for reference only.

This manual covers installation of sensors in the conventional manner (see below). For inverted installation (see below) please contact Gill Sensors & Controls Limited.

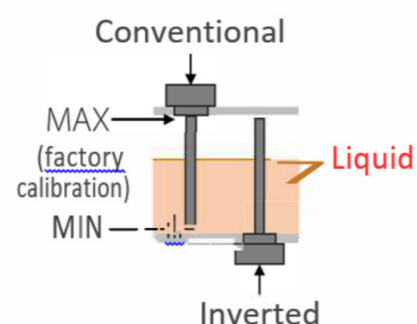

LevelLite can be mounted using a variety of 1 hole, 2 hole, 3 hole, 5 hole and threaded adaptors. An O-ring seal is used for 1 hole (and may be used for 2/3/5 hole) adaptors, while a panel gasket is used for 2/3/5 hole adaptors.

The sensor must be installed on a flat surface, such that it occupies the deepest part of the tank to be measured.

The sensor can be installed at any angle from vertical to a maximum recommended angle of 45°. Ensure that the mounting hole in the tank is strong enough to withstand the forces imposed by the sensor from its weight and the vibrations it may be exposed to. Please contact Gill Sensor & Controls Limited to discuss specific sensor requirements when mounted at an angle.

Before installation, ensure you have sufficient clearance above the tank in to order to mount the sensor. The sensor is rigid, therefore the clearance height must be, at a minimum, the designated length of the sensor plus 20mm for side exit cable sensors and plus 60mm for top exit cable sensors. Sideways clearance may also be required, and should be accounted for.

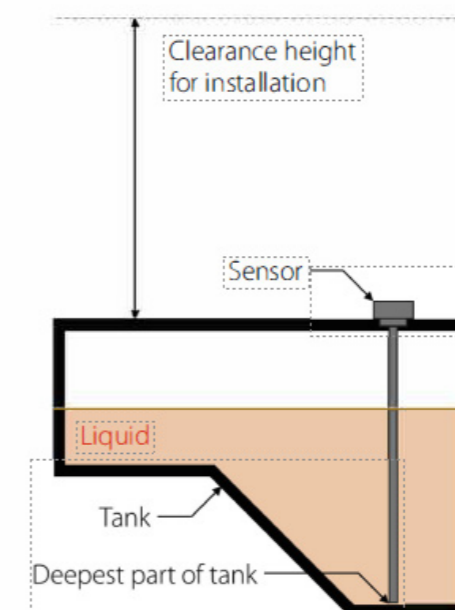

#### 4.1 Parts supplied

LevelLite Lightweight Liquid Level Sensor  
O-ring seal(s) and/or panel gasket (2/3/5 hole as required)  
Adaptor M3x6 CSK screws (qty. 3)  
Quick Start Guide

#### 4.2 Cable length & strain relief

The sensor is provided with a flying lead of 1000mm, which may be shortened appropriate to the application. Ensure that the cable is secured to avoid damage during operation. It is recommended that cable length is kept to a minimum to prevent large voltage drops over the length of the cable which may affect the operation of the sensor.

Cable strain relief is provided at the sensor. Care should be taken not to stress the cable at the cable entry. The minimum recommended cable bend radius is 40mm. It is recommended that you do not connect the cable before installation.

#### 4.3 Fitting the mounting adaptor

##### 4.3.1 Fitting the 19 x 1.5 mm fluorosilicone O-ring seal

Prior to installation of the sensor in the tank a fluorosilicone O-ring seal and/or fluorosilicone panel gasket must be fitted to ensure the tank is sealed. All sensors must be fitted with the 19 x 1.5 mm fluorosilicone O-ring seal as shown in the diagram below.

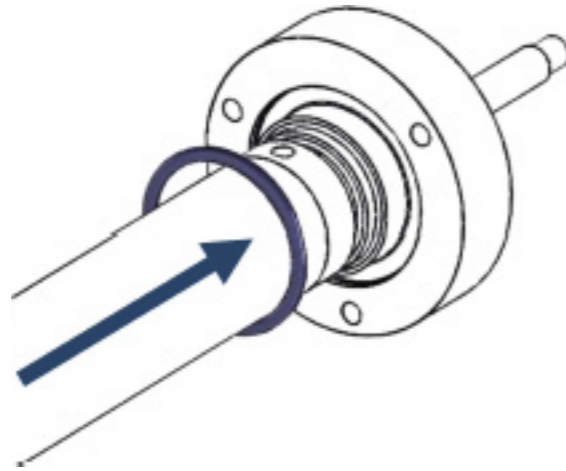

#### 4.3.2 Fitting the sensor adaptor

The sensor must then be fitted with the adaptor (1, 2, 3, 5 hole or threaded adaptor) using the three supplied M3 x 6 mm CSK screws as shown in the diagram below. The adaptor has 3 possible orientations for 1, 2, 3 hole and threaded adaptors - for the correct orientation of the 5 hole adaptor see the diagram on the next page. (Note: Thread lock pre-applied to screws. Tighten to 1.3 Nm with 2.0 mm Hex Key.)

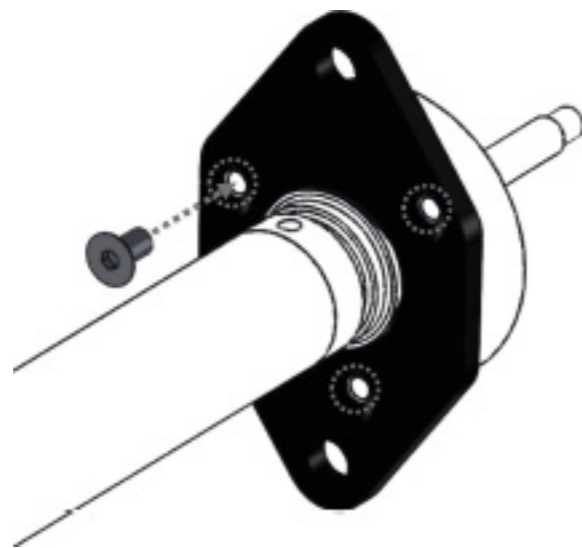

For top exit cable sensors any orientation may be used. For side exit cable sensors using the 5 hole adaptor, the orientation shown in the diagram below must be used. Align the adaptor and sensor such that the three smaller adaptor fitting holes align with their holes in the sensor and the cable is in the position shown.

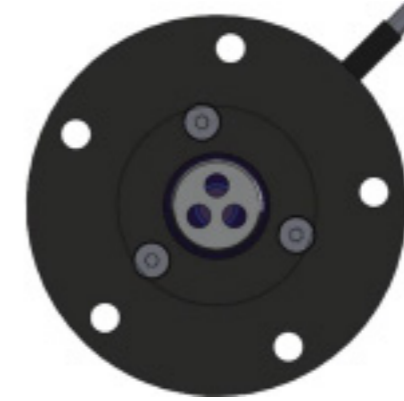

#### 4.3.3 Fitting the fluorosilicone panel gasket or fluorosilicone 13 x 1.5 mm O-ring seal

You can use the fluorosilicone panel gasket with the 2, 3 or 5 hole adaptors. Fit the panel gasket as shown in the diagram below such that holes in the panel gasket line up with the mounting holes of the adaptor. (Note: if you are using the panel gasket you do not need the 13 x 1.5 mm O-ring)

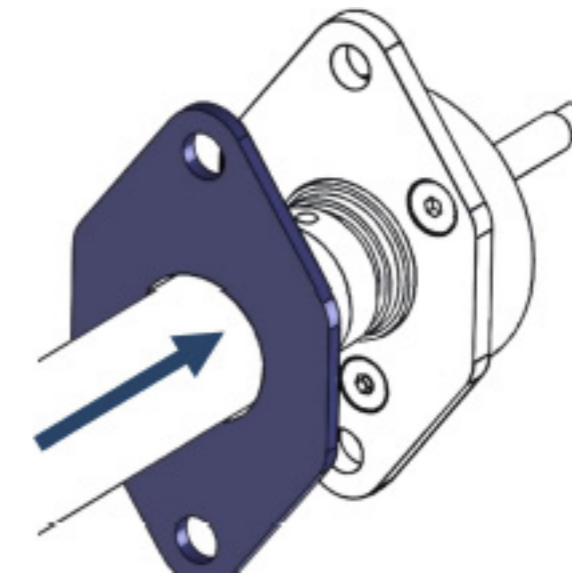

You can use the fluorosilicone O-ring seal with the 1, 2, 3 or 5 hole and the threaded adaptors. Fit the 13 x 1.5 mm fluorosilicone O-ring seal in the position shown in the diagram below. (Note: if you are using the 13 x 1.5 mm O-ring you do not need the panel gasket)

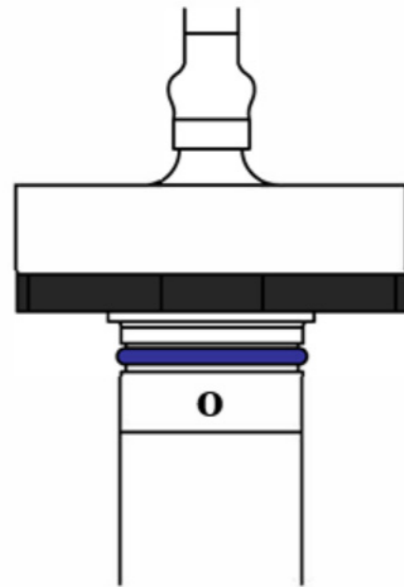

The sensor is now ready for installation into the tank.

4.4 Recommended mounting aperture for adaptors

4.4.1 For O-ring seal with 1, 2, 3 and 5 hole mounting adaptors

The recommended mounting aperture and chamfer size for use with the O-ring seal and 1, 2, 3 and 5 hole adaptors is shown below. Ensure that sufficient space is available around the sensor flange for the cable to bend.

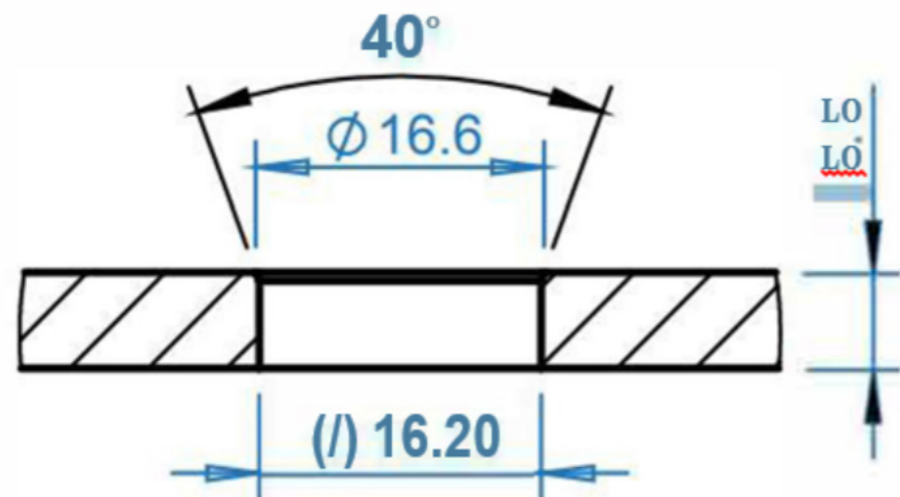

4.4.2 For panel gasket with 2, 3 and 5 hole mounting adaptors

The recommended mounting aperture for use with the panel gasket and 2, 3 and 5 hole adaptors is shown below. Ensure that sufficient space is available around the sensor flange for the cable to bend.

*Note: all panel gaskets are 2 mm thick*

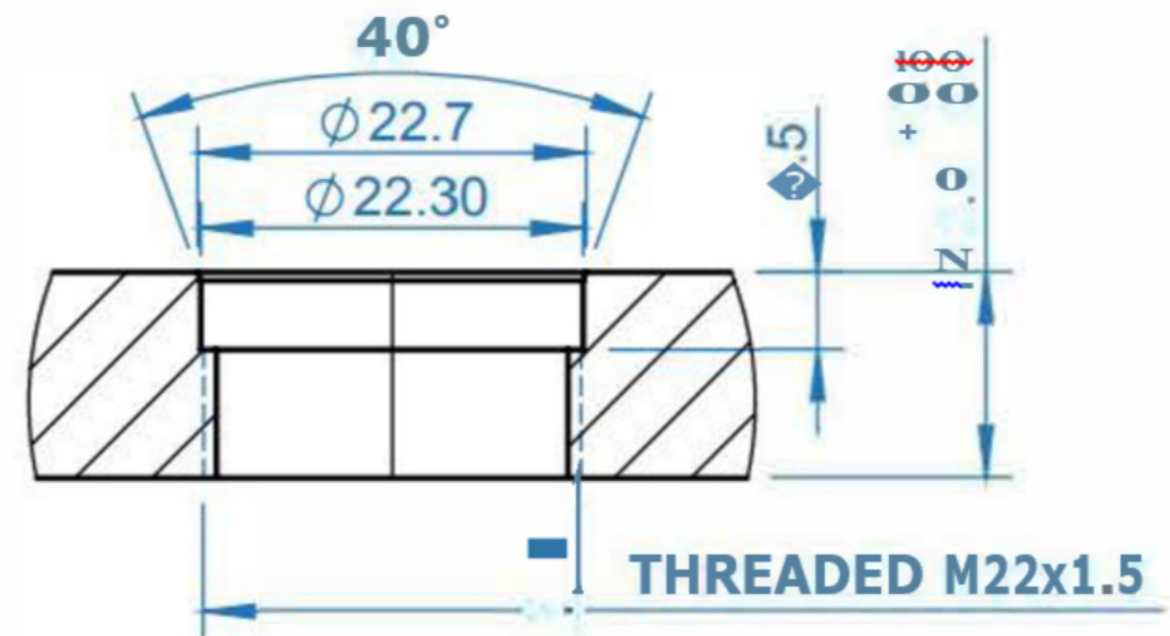

4.5 Mounting adaptor hole layout

To fix the mounting adaptor to the tank, you will be required to tap suitable holes into the tank wall. Ensure that the tapped holes do not penetrate entirely through the tank wall as this will prevent a proper seal from being maintained.

A diagram of each mounting adaptor is provided below to enable the holes to be tapped in the correct position. In the case of the threaded flange mounting adaptor, a cross sectional view has also been provided for greater detail.

4.5.1 One Hole mounting adaptor

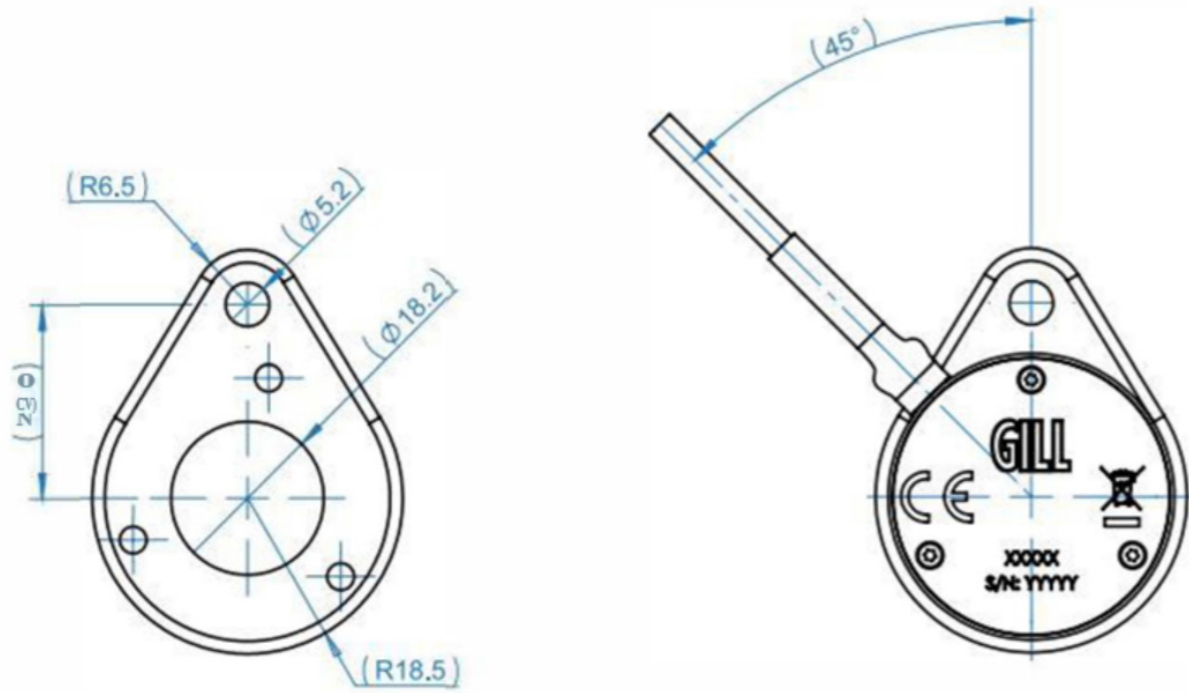

4.5.2 Two hole mounting adaptor

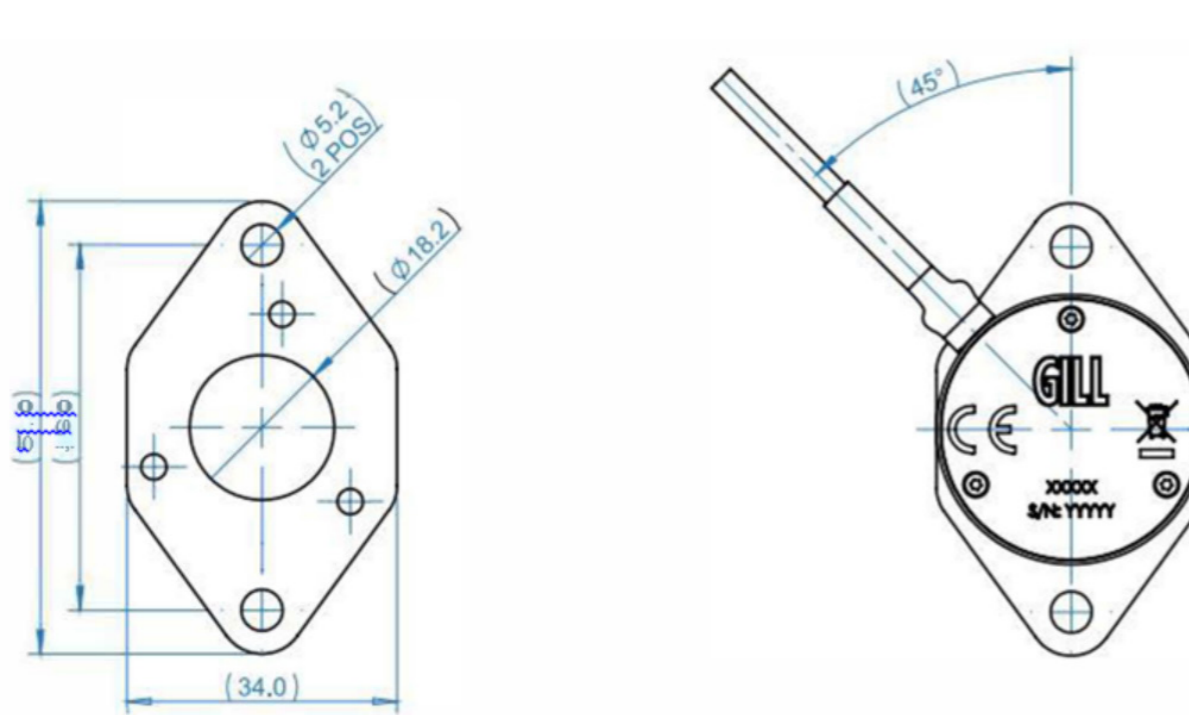

4.5.3 Three hole mounting adaptor

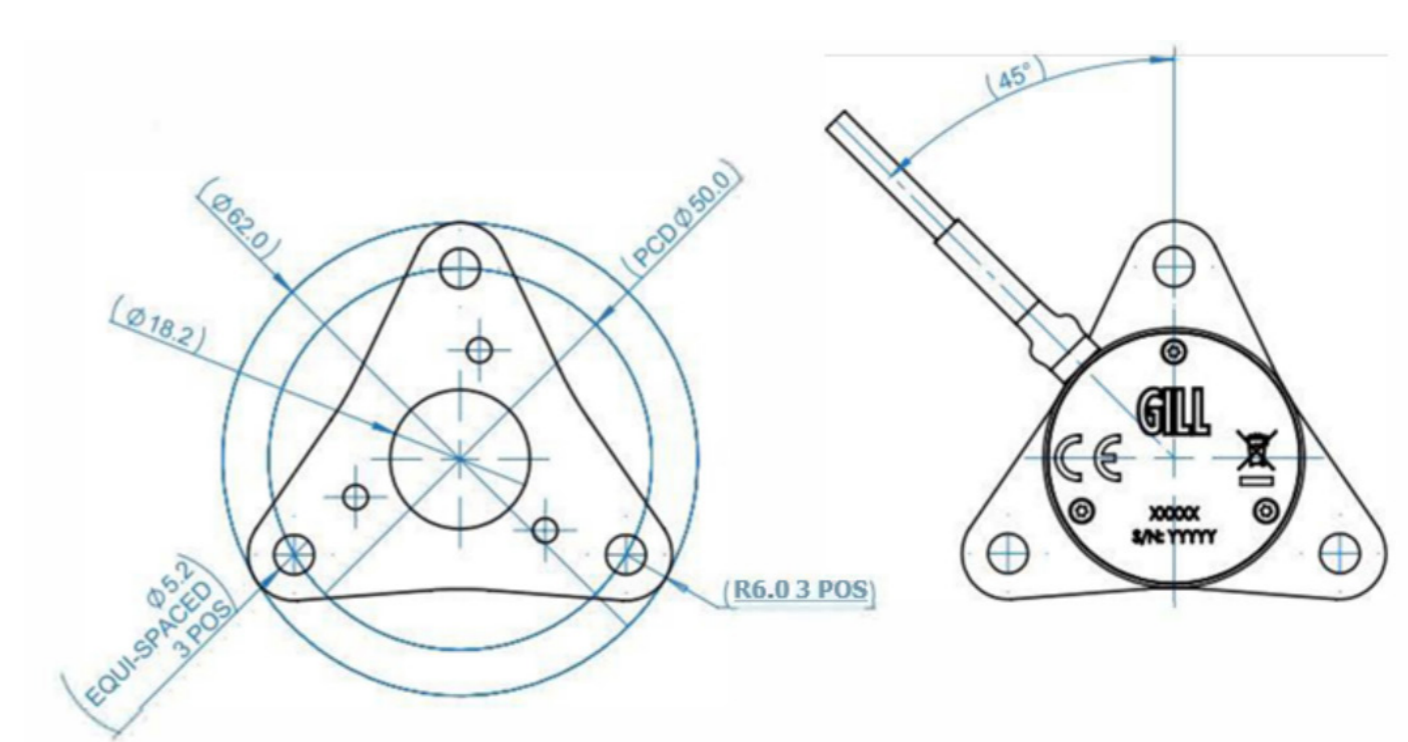

4.5.4 Five hole mounting adaptor

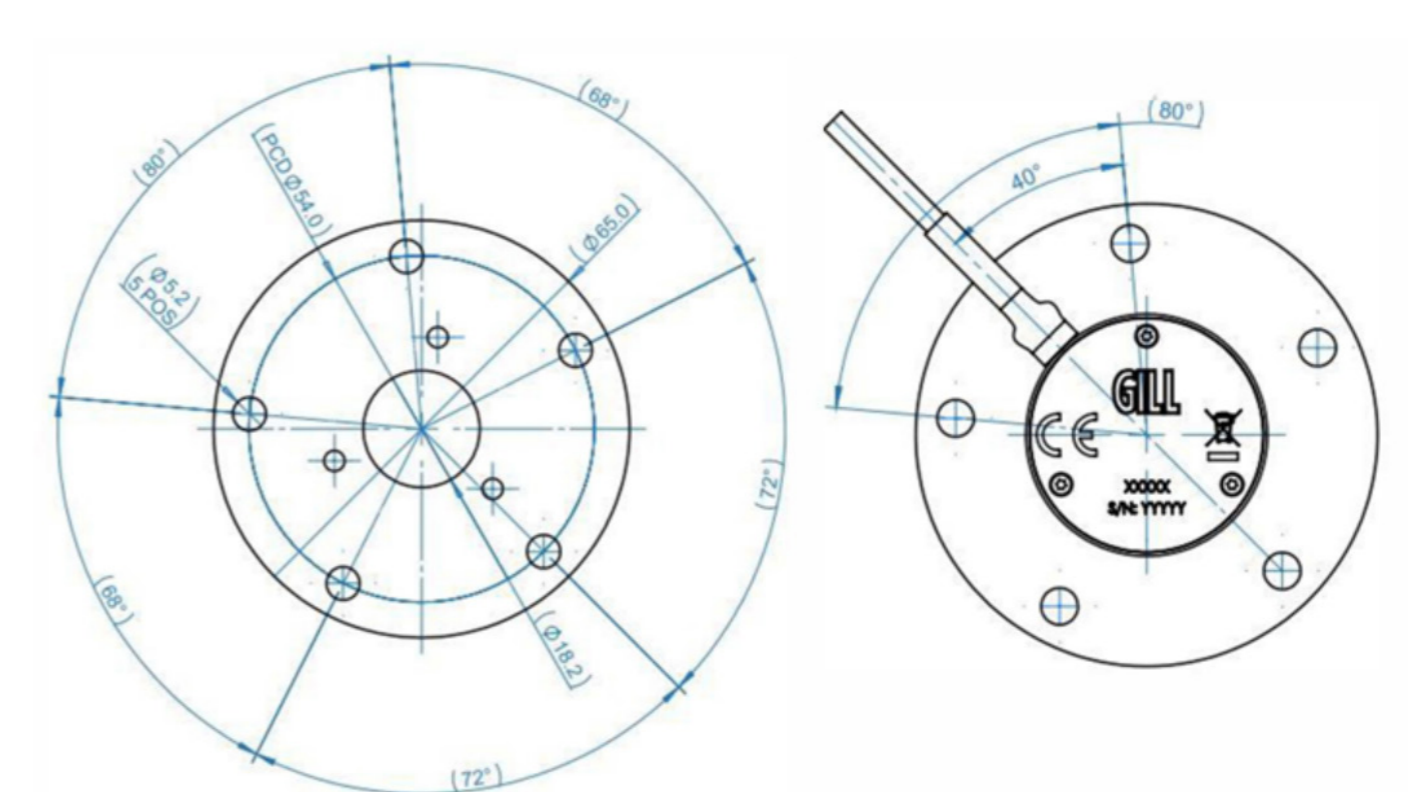



4.5.5 M22 x 1.5 mm threaded flange mounting adaptor

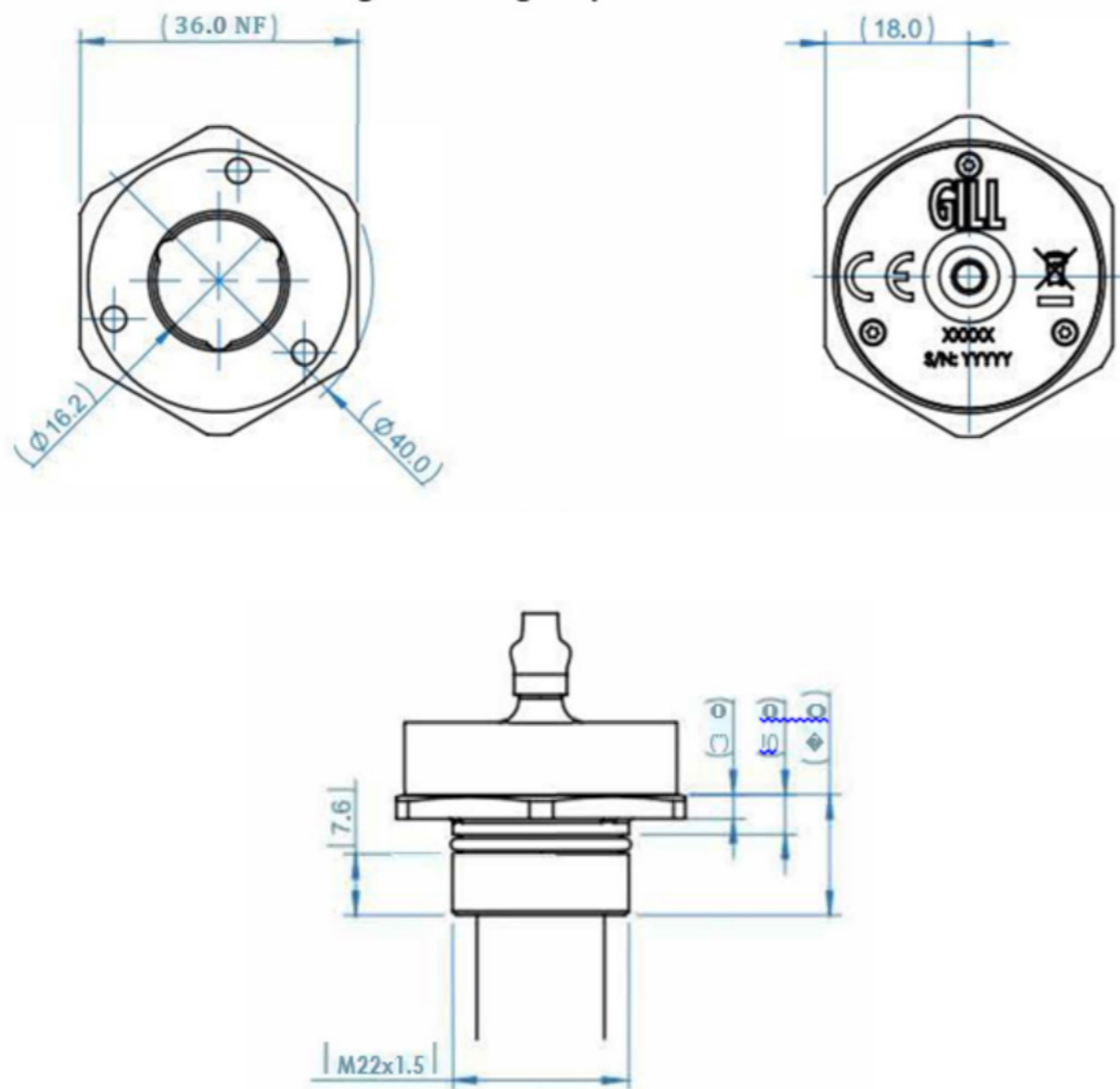

**5 Specifications**

**5.1 General**

Primary output accuracy:	±1%@ 50% FSD (full scale deflection) 20°C
Secondary output hysteresis (option N):	Configurable through GSlevel software
Secondary output accuracy (option Y):	± 1.5°C between 0°C and + 125°C ±2.0°C between -40°C and 0°C
Compatible media:	Fuels (Diesel, Gasoline, Biofuels); Oils (Hydraulic, Gear, Motor, Vegetable, Synthetic Ester, Polyalphaolefin, Polyglycol); Coolants (Ethylene Glycol, Water); Salt water

**5.2 Environmental**

Ingress protection: Shock tested to:	IP68 BS EN 60068-2-27 (half-sine pulse 25g, 6ms 1000 shocks [positive and negative] in each of 3 axes)
Vibration tested:	Resonant frequency search 5 to 2500Hz@ 0.5g peak
Pressure	10 bar (absolute and differential)
Compatible media:	1 m (in packaging) on all 3 sides
Thermal shock:	to BS EN 60068-2-14, test Na
Dry heat	to BS EN 60068-2-2, test Bb
Cold	to BS EN 60068-2-1, test Ab
to BS EN 60068-2-1, test Ab	to BS EN 60068-2-30, test Db
EMC immunity:	BS EN 60945, BS EN 61326 and BS EN 61000-6-1/2/3/4

**5.3 Mechanical**

Probe length:	100 to 750 mm
Mounting options:	1 hole, 2 hole, 3 hole, 5 hole and M22x1.5 threaded Panel gasket or O-ring seal
Sealing options:	Panel gasket or O-ring seal: ±2.0°C between -40°C and 0°C
Cable exit options:	Top or side
Weight:	36.5g (100mm probe with 1 000mm cable) + 0.34g per additional mm (probe)

5.4 Electrical

Supply voltage:	5-32 VDC
Supply current:	100 to 750 mA
Interface:	Compatible with RS232
Resolution:	10 bit (1024 points over measurement range)
Sample rate	100 Hz

5.5 Connection

Cable	Flying lead, 1000mm
Number of cores:	6 with drain wire
Wire size	26AWG7/0/15
Sleeving	XLPE

5.6 Part number configuration

The configuration of the sensor can be determined from its part number designation, engraved on the flange lid. The interpretation of the part number designation is outlined below.

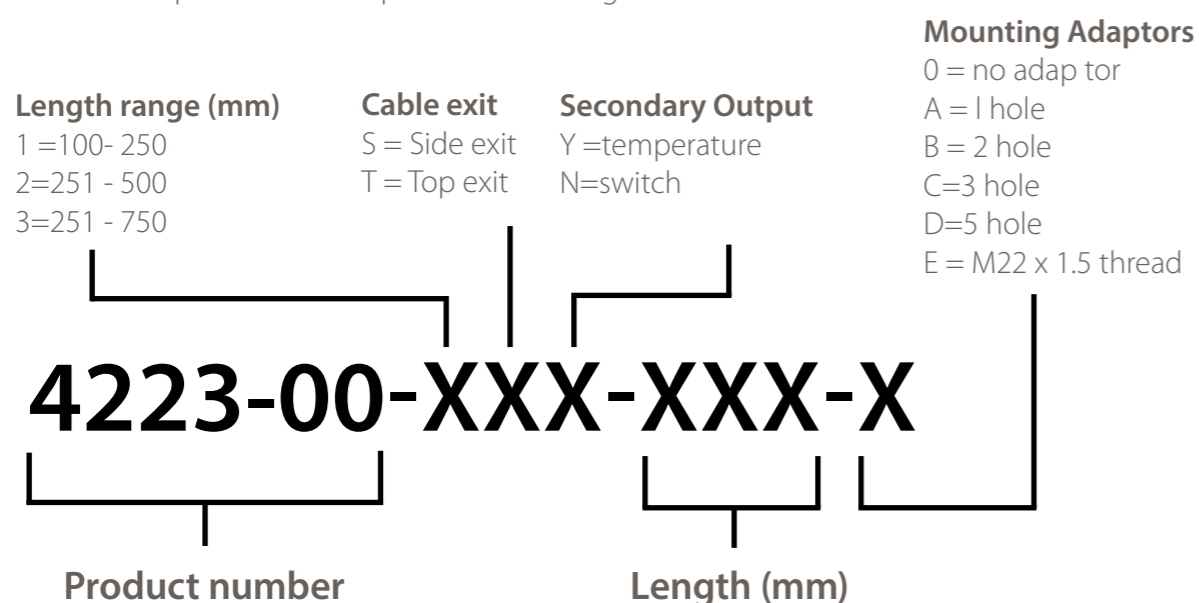

6. Maintenance, returns & de-commissioning

6.1 Maintenance

The sensor requires no maintenance. There are no customer serviceable or moving parts within this sensor. Faults in operation are most likely to occur if the sensor is incorrectly configured during installation. Configuring the measurement output or the tank profiling incorrectly will cause the reported output to be incorrect. A bad configuration may prevent any output being reported. If any faults with the sensor occur, please contact Gill Sensors & Controls Limited. Contact details can be found at [gillsc.com](http://gillsc.com).

6.2 Returns

If Gill Sensors & Controls Limited require the sensor to be returned, you will be issued with an RMA number. Please DO NOT return the sensor without having first obtained an RMA number. This will enable your sensor to be tracked and updates provided.

6.3 Decommissioning

To dispose of the sensor, follow local waste disposal regulations.

To uninstall the GSlevel software launch the 'Uninstall GSlevel' application from your program file location selected during installation.

Alternatively, open 'Control Panel > Programs> Programs and Features' and select the 'GSlevel VX.X.X' from the list and select the Uninstall option to remove the GSlevel configurator software from your PC.

7. Appendix

Gill Sensors & Controls

EU Declaration of Conformity



In accordance with the following CE Directives:



2014/30/EU (Electromagnetic Compatibility – EMC)  
2011/65/EU (Restriction of Hazardous Substances – RoHS)

We, Gill Sensors & Controls Ltd, declare under our sole responsibility that the products:

**GS Level 4223 - Lightweight Liquid Level Sensor (all variants as detailed below):**

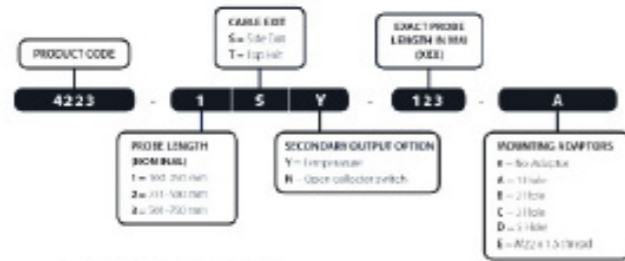

Manufactured by: Gill Sensors & Controls Ltd,  
Unit 630 Ampress Park  
Lymington,  
Hampshire, UK  
SO41 8JW

To which this declaration relates, are in conformity with the protection requirements of Council Directive 2014/53/EU on the approximation of the laws relating to electromagnetic compatibility. This Declaration of Conformity is based upon compliance of the product with the following harmonised standards:

Marine	EN 60945:2002 EN 61326-1:2013
Light Industrial	EN 61000-6-3:2007 EN 61000-6-4:2007
Measurement Control	EN 61326-1:2013 Table 2 EN 61000-6-2:2007
Heavy Industrial	EN 61000-6-2:2005

Gill Sensors & Controls Limited certifies that the 4223 liquid level sensor is compliant with the European Union's Restriction on the Use of Hazardous Substances in Electrical and Electronic Equipment (RoHS II) Directive 2011/65/EC by absence of hazardous materials specified herein.

Restriction of Hazardous Substances EN 50581:2012

Signed by:   
Print Name: C. Whight - Director of Group Operations  
Date of issue: 15/06/2017  
Place of issue: Gill Sensors & Controls Ltd, Unit 630 Ampress Park, Lymington, Hampshire, UK SO41 8JW

Change Notice 359

Doc no. 3002 248 10.2



IMPORTANT NOTICES

- Gill Sensors & Controls Limited can take no responsibility for installation and/or use of its equipment if this is not done in accordance with the appropriate issue and/or amendment of the manual.
- The user of this manual should ensure that it is appropriate in all details to the exact equipment to be installed and/or operated. If in doubt, the user should contact Gill Sensors & Controls Limited for advice.
- If further details are required which do not appear in this manual, contact Gill Sensors & Controls Limited or one of their agents.
- Install and use LevelLite Lightweight Liquid Level Sensor in accordance with local regulations.
- Gill Sensors & Controls Limited are continually enhancing their products and specifications and reserve the right to change or revise the information supplied in this document without notice and without obligation to notify any person or organisation of such revision or change.
- The information contained in this manual remains the property of Gill Sensors & Controls Limited and should not be copied or reproduced for commercial gain.

HELP US TO HELP YOU:

Every effort has been made to ensure the accuracy in the content of our documents, however, Gill Sensors & Controls Limited can assume no responsibility for any errors or omissions in our documents or their consequences. Gill Sensors & Controls Limited would greatly appreciate being informed of any error or omissions that may be found in the contents of any of our documents.

After sales support

Should you require after sales assistance with this product, please go to [www.gillsc.com](http://www.gillsc.com) where you can request support by clicking on the "Get Support" button and filling out the form. Alternatively, call us during UK office hours on 01590 613900 (UK). Please have details of the product and serial number whenever possible.

